



Model SGC Counter Top Tube Fired Gas Fryer



STANDARD ACCESSORIES

- Standard #14 baskets
- One nickel plated tube rack
- One drain line clean-out rod
- One drain extension
- Fryer cleaner sample
- Rear gas connection
- Manual gas shut off
- 1 1/4" (3.2 cm) full port drain valve
- Built-in integrated flue deflector
- Removable basket hanger for easy cleaning
- Cabinet - Stainless steel front, door, and sides
- Tank - stainless steel
- 4" Removable legs

AVAILABLE OPTIONS & ACCESSORIES

- Stainless steel back
- Fryer Covers

Project _____

Item number _____

Quantity _____

Model SGC - Counter Top Fryer

STANDARD SPECIFICATIONS

CONSTRUCTION

- Welded tank with a super smooth machine peened finish ensures easy cleaning.
- Long lasting, high temperature alloy stainless steel heat baffles are mounted in the heat exchanger tubes to provide maximum heating and combustion efficiency.
- Standing pilot light design provides a ready flame when heat is required.
- Heavy duty 3/16" (.48 cm) door hinge.

CONTROLS

- Millivolt thermostat maintains selected temperature automatically between 200°F (93°C) and 400°F (190°C-CE).
- Integrated gas control valve acts as a manual and pilot valve, automatic pilot valve, gas filter, pressure regulator, and automatic main valve.
- Gas control valve prevents gas flow to the main burner until pilot is established and shuts off all gas flow automatically if the pilot flame goes out.
- Temperature limit switch safely shuts off all gas flow if the fryer temperature exceeds the upper limit.
- New Solstice burner/baffle design.***
 - Increases cooking production.
 - Lowers flue temperature.
 - Improves working environment.
 - Generates more production per BTU.
 ***Compared to previous models.

OPERATIONS

- Standing pilot and thermostat maintain temperature automatically at the selected temperature (between 200°F (93°C) and 400°F (204°C)).
- Front 1-1/4" (3.2cm) NPT full port drain, for quick draining.

APPROVALS

- CSA Certified (AGA, CGA)
- NSF Listed
- MEA Approved



Patent Pending



Pitco Frialator, Inc., P.O. Box 501, Concord, NH 03302-0501 • 509 Route 3A, Bow NH 03304, USA
Phone (800) 258-3708 • (603) 225-6684 • Fax (603) 225-8472 • www.pitco.com

L10-145 Rev 3 (05/03)



Model SGC - Counter Top Fryer

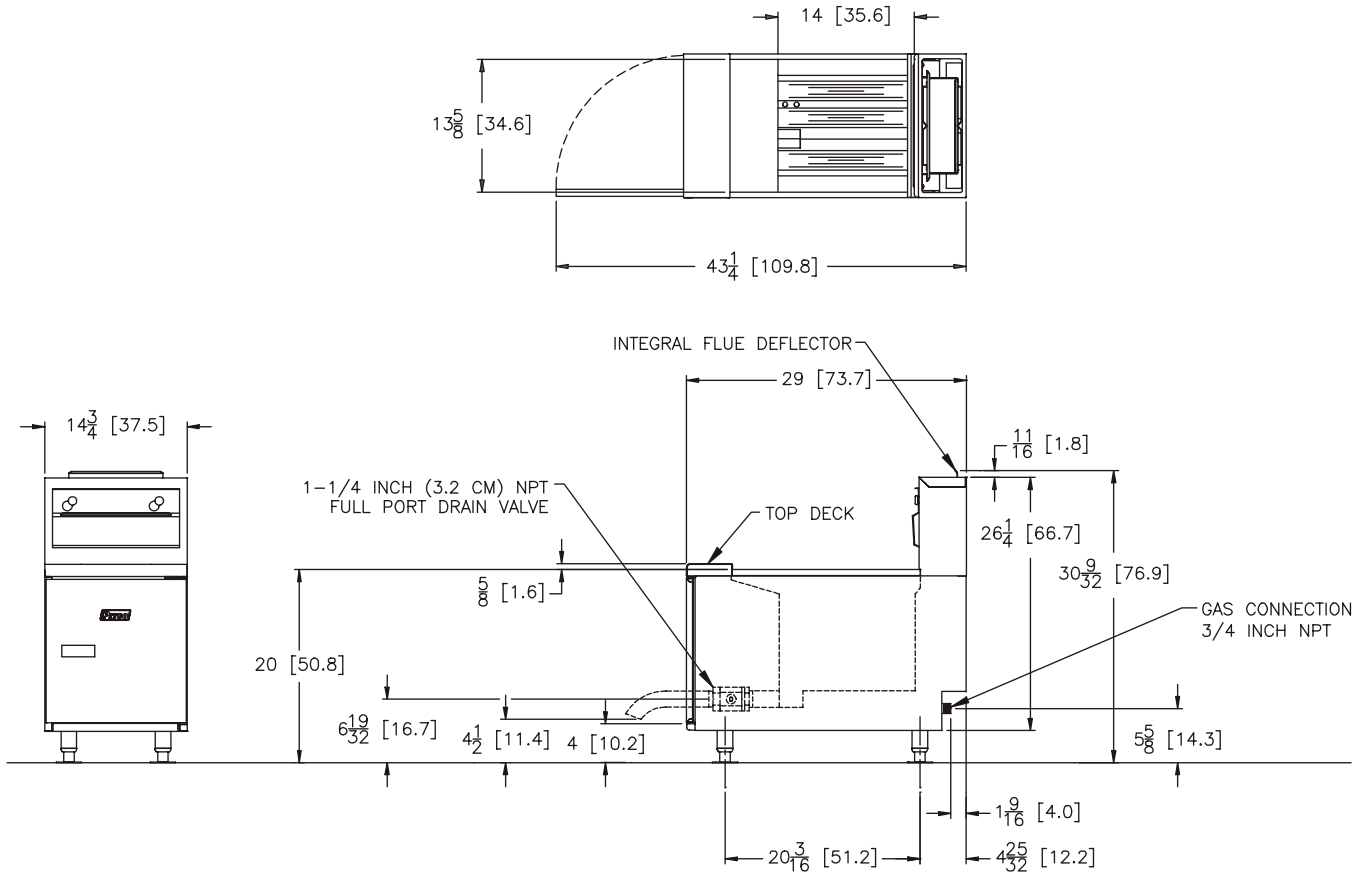

4" Legs can be adjusted up to 5"
 4" Legs can be removed and unit can be flush mounted on a flat surface

ELECTRICAL			OIL CAPACITY		
Control Type	VOLTAGE/PHASE/HZ		35 pounds (15.9 KG)		
	120/1/60	240/1/50	SHIPPING INFORMATION		
	AMPS/EA	AMPS/EA			
Millivolt	n/a	n/a	Weight 150 Lbs (60KG)	Cube 17.1 ft ³ (.48 m ³)	Ship H x W x L 35 x 22.5 x 37.5(89 x 57.2 x 95.3)
GAS CONSUMPTION			PERFORMANCE CHARACTERISTICS		
75,000 BTU's/Hour (32.2KWH/ 79.1megajoules)			Cooks 62 lbs (28.1 KG) of fries per hour Frying Area is 14" x 13-5/8" (35.6 cm x 34.6 cm)		

SHORT FORM SPECIFICATION

Provide Pitco Model SGC Counter tube fired gas fryer. Fryer shall have an atmospheric burner system combined with three stainless steel heat tubes utilizing high temperature alloy stainless steel baffles. Fryer shall have deep a cool zone; minimum 20% of total oil capacity. Fryer cooking area shall be 14" x 13-5/8" (35.6 cm x 34.6 cm) with a cooking depth of 4" (10.2 cm). Heat transfer area shall be a minimum of 450 square inches (2,903 sq cm). Provide accessories as follows:

TYPICAL APPLICATION

Frying a wide variety of foods in a limited amount of space. Counter top frying that uses less than 14-3/4" (37.5 cm) of counter space. Frying that requires a medium volume production rate.

